

Grey Birch MFG

La Chassis 457 Manual



GREY BIRCH MFG INC. TAMPA, FLORIDA, USA.
Available Worldwide.

If you were competing in the championship tomorrow



you'd carry a **Grey Birch.**

When the pressure is on and every shot counts, accuracy and speed matter most.

That's why the Grey Birch La Chassis 457 & T1X is used by competition shooters who prefer to stand atop the podium. The La Chassis is built using 6061 T6 aluminum, one of the lightest and most rigid materials on planet earth. This means that a professional shooter can hit their targets all day long without getting fatigued. The competition results speak for themselves.



GREY BIRCH MFG INC. TAMPA, FLORIDA, USA.
Available Worldwide.

GREY BIRCH HEADQUARTERS



All Grey Birch products are made in Tampa, Florida with an obsessive focus on design and functionality.

When you purchase a Grey Birch product, not only are you supporting a small business directly, you are supporting many small businesses indirectly.

By manufacturing locally, it allows us to be as close to the process as possible to ensure the highest level of quality is achieved.

We are confident and proud to be putting out world class products that you can enjoy for a lifetime...

— **You never really own a Grey Birch, you simply take care of it for the next generation** —

Welcome to the Grey Birch family.

-Jeff & Steve



FIREARM SAFETY

We take firearm safety dead serious. Literally.

- Assume every firearm is loaded.
- Control the muzzle direction at all times.
- Always point your firearm in a safe direction.

Remove the magazine from the firearm.

- Observe the chamber to ensure it is empty.
- Open the bolt and remove from the action if possible.
- Once your firearm has been proven safe you can begin modifying or cleaning.

Please ensure approved eye and ear protection is worn at all times.

*Be aware of the laws in your country and region concerning overall rifle length and folding stocks. It is up to you — the end user — to ensure you maintain compliance.

Grey Birch ships all stocks in the fixed position.



INSTALLING THE TRIGGER GUARD

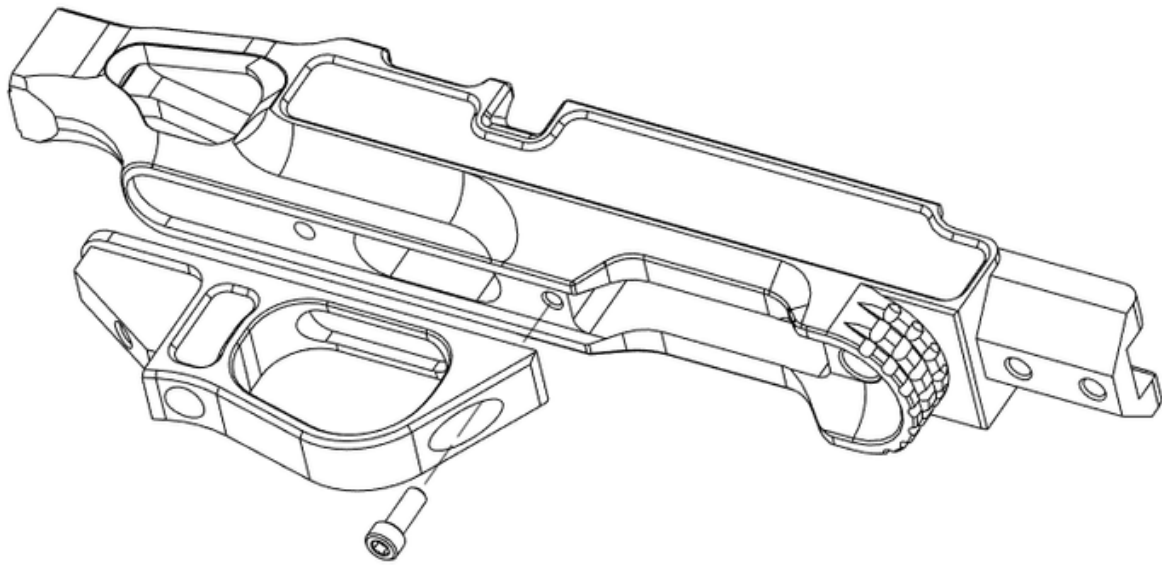

Steps to follow

- Remove your CZ457 barreled action from the factory stock by unscrewing the two screws in the trigger guard. You will not require these screws for the install.
- Once the screws are removed, remove the barreled action and re-install into LaChassis 457. The safest method is to rest the barreled action upside down on a flat surface and place the chassis on top of it.
- With the chassis laying on the barreled action, insert the included action screws. The longer screw goes in the rear of the trigger guard, the shorter screw goes in front of the magazine.
- Using a 5/32" hex key, tighten the action screws to 25 in/lb starting with the trigger guard screw.



INSTALLING OR REMOVING THE FOREND

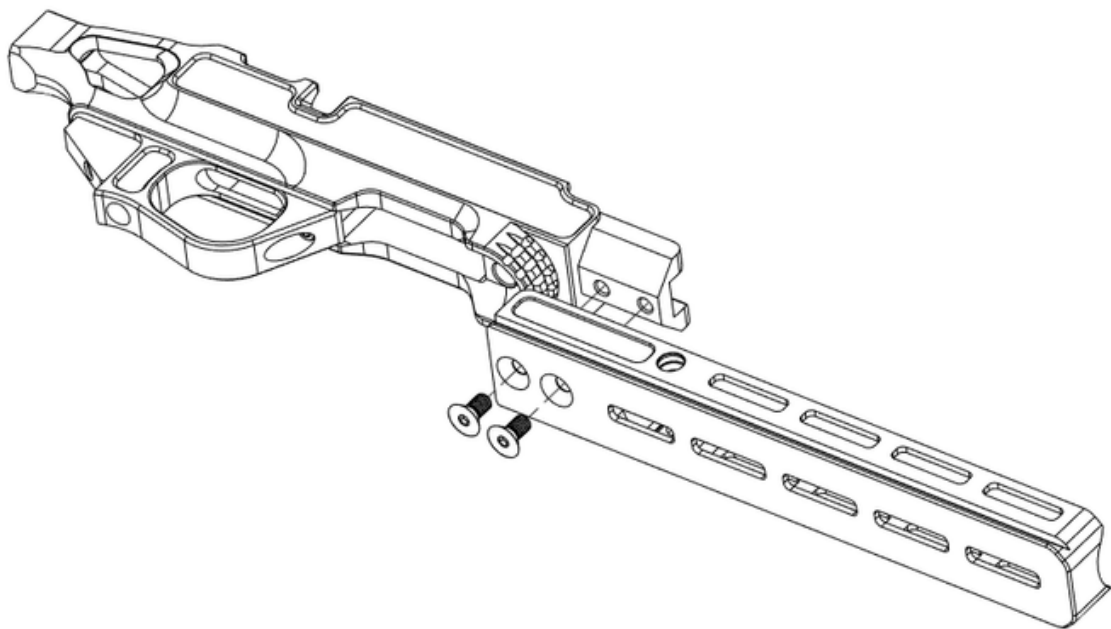

Steps to follow

- Slide the forend over the dove tail on the front of the chassis.
- You may need to slightly wiggle it while sliding it on. (“That’s what she said” - Michael G. Scott)
- When the forend is in place, install the screw using a 3/32” hex key and tighten to 30 in/lbs.
- Do not over tighten as it may damage the threads of the forend.
- To remove the forend, follow these steps in reverse.



INSTALLING THE ACTION INTO THE CHASSIS

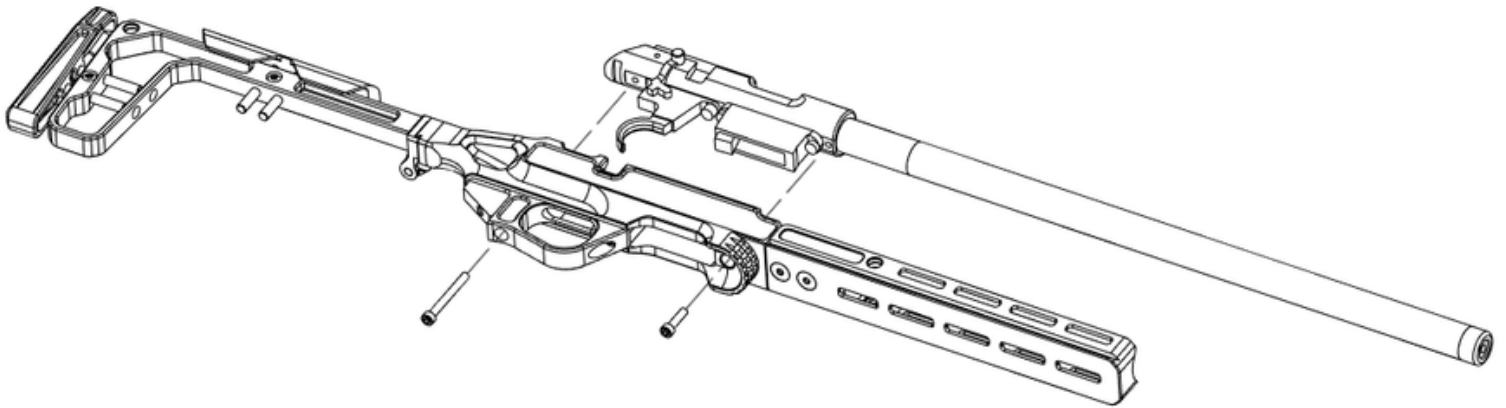

Steps to follow

- Remove your CZ457 barreled action from the factory stock by unscrewing the two screws in the trigger guard. You will not require these screws for the install.
- Once the screws are removed, remove the barreled action and re-install into LaChassis 457. The safest method is to rest the barreled action upside down on a flat surface and place the chassis on top of it.
- With the chassis laying on the barreled action, insert the included action screws. The longer screw goes in the rear of the trigger guard, the shorter screw goes in front of the magazine.
- Using a 5/32" hex key, tighten the action screws to 30 in/lb starting with the trigger guard screw.



INSTALLING OR REMOVING THE STOCK

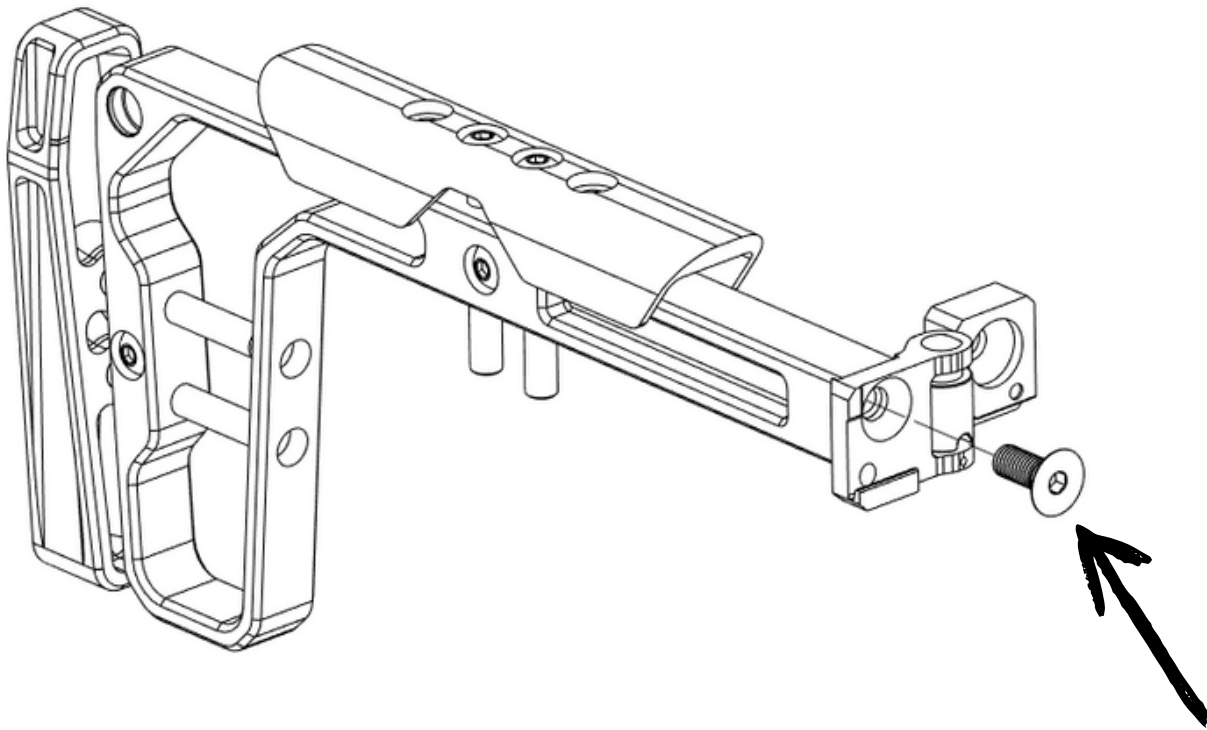

Steps to follow

- Place folding adapter assembly with the corresponding outline (square) on the front of the stock and secure with 30 in/lb with a 5/32
- Do the same on the back of the chassis and secure with 30 in/lb with a 5/32
-



ADJUSTING THE CHEEK WELD LOCATION

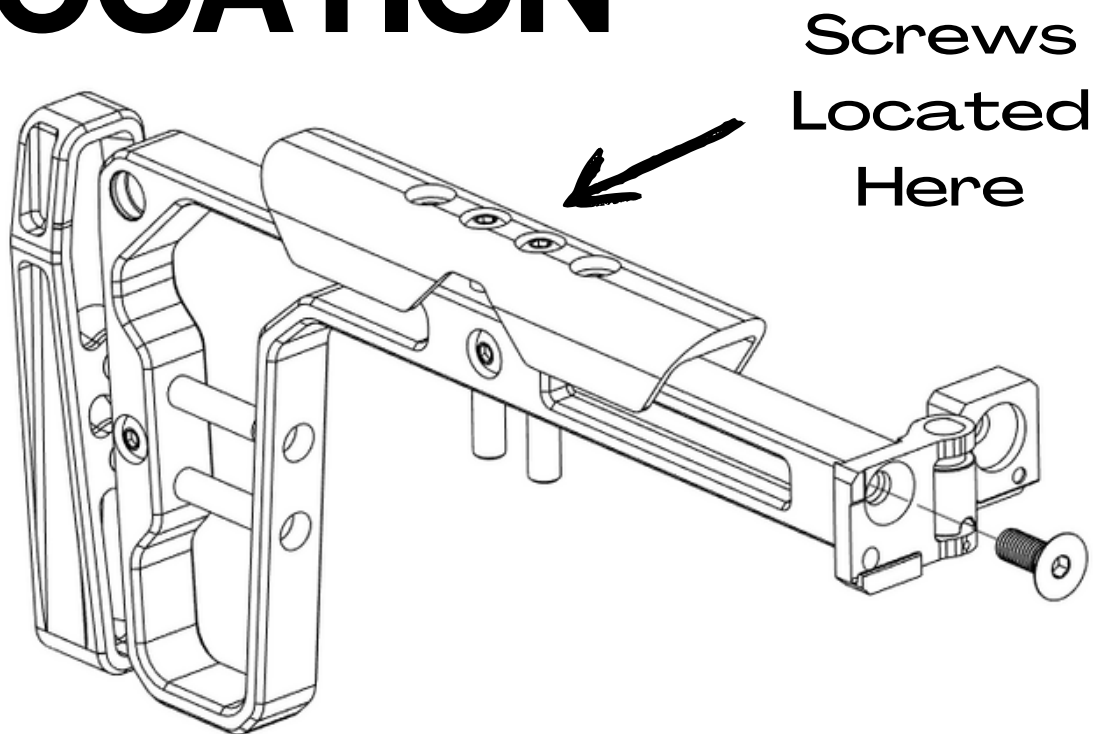

Steps to follow

- Using a 1/8" hex key, remove the two screws on the top of the cheek weld. Don't lose those pillars.
- With the screws removed, shift the position of the cheek weld forward or backwards as desired.
- With the cheek weld in position, tighten the two screws through the cheek weld into the pillars behind it.
- Hand tighten only.



ADJUSTING THE CHEEK WELD HEIGHT

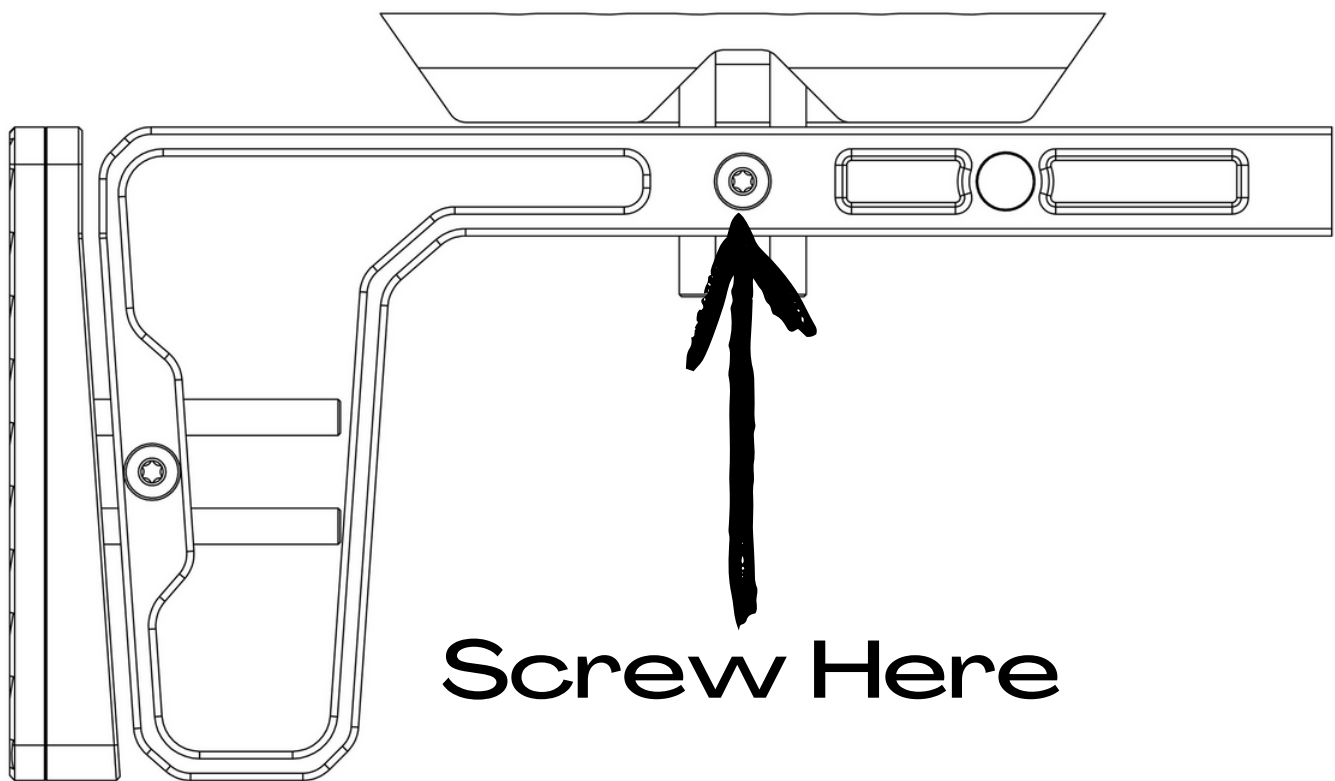

Steps to follow

- Using a 1/8" hex key, loosen off the screw to allow vertical movement of the check weld.
- When the desired height is achieved, tighten the screw to hand tight.
- Do not over tighten as it can damage the threads on the backer plate.
- Tighten to max 10 in/lbs.



ADJUSTING THE LENGTH OF PULL

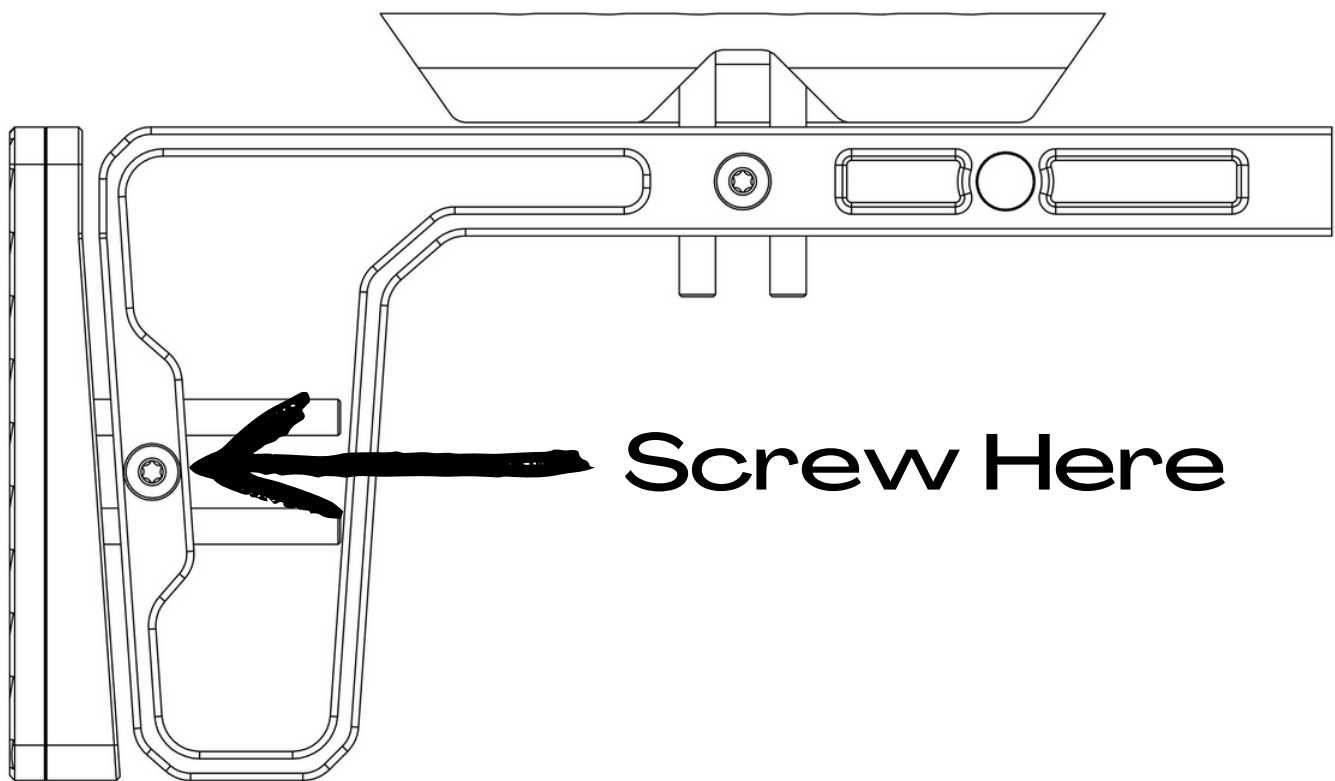

Steps to follow

- Using a 1/8" hex key, loosen off the screw to allow horizontal movement of the shoulder plate.
- When the desired length of pull is achieved, tighten the screw to hand tight.
- Do not over tighten as it can damage the threads on the backer plate.
- Tighten to 10 in/lbs.



OPERATING THE FOLDING STOCK

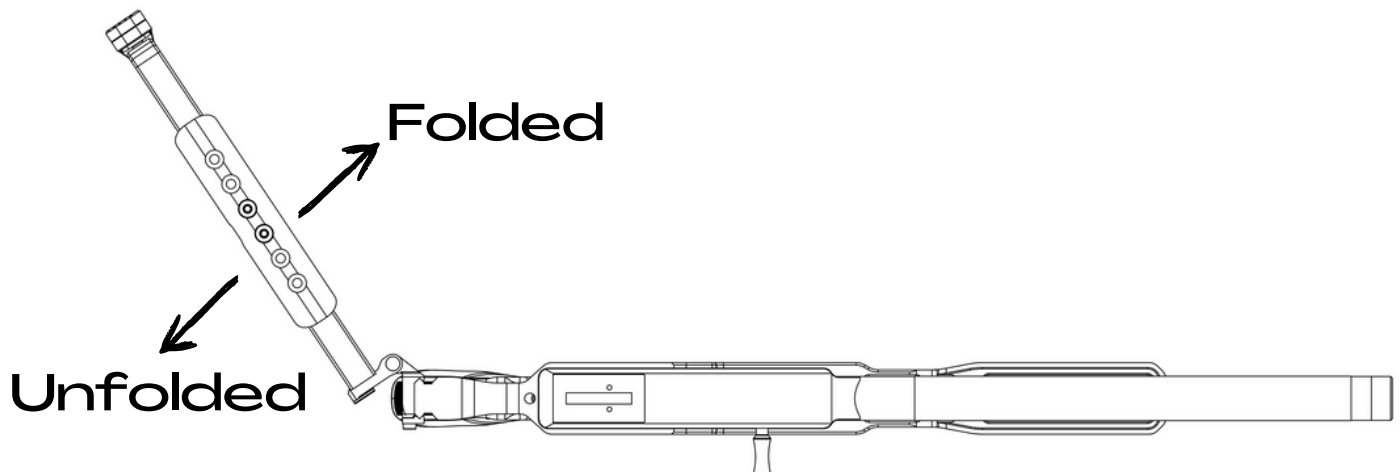
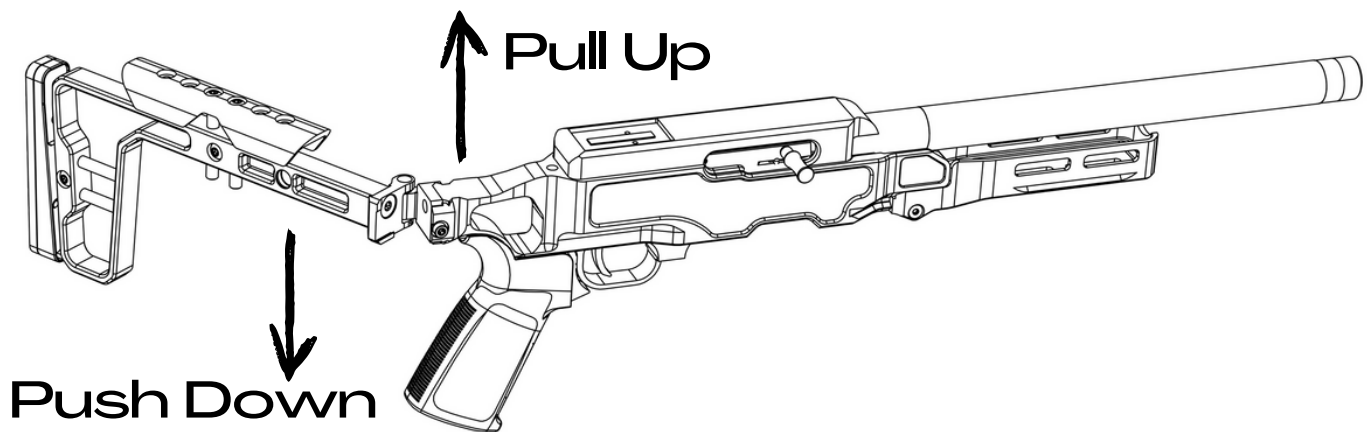

Steps to follow

- Push the stock down while lifting the rifle up.
- The stock will swing towards the rifle into the folded position.
- To unfold the stock, swing the stock away from the rifle and it will lock into position.

A stylized world map in shades of purple and teal, centered on the Atlantic Ocean, set against a black background. The text "Available Worldwide" is overlaid in the center of the map.

Available WorldWide



GREY BIRCH MFG INC. TAMPA, FLORIDA, USA.
Available Worldwide.